



BALDOR® • *RELIANCE*

Product Information Packet

CESSWDM3615T

5HP,1750RPM,3PH,60HZ,184TC,3646M,TEFC,F1

Product Detail							
Revision:	B	Status:	PRD/A	Change #:		Proprietary:	No
Type:	AC	Prod Type:	3646M	Elec. Spec:	36WGY754	CD Diagram:	CD0005
Enclosure	TEFC	Mfg Plant:		Mech Spec:	36L738	Layout:	36LYL738
Frame:	184TC	Mounting:	F1	Poles:	04	Created Date:	07-13-2006
Base:	RG	Rotation:	R	Insulation:	F	Eff. Date:	11-22-2006
Leads:	9#16	Literature:		Elec. Diagram:		Replaced By:	

Parts List			
Product ID	Description	Quantity	List Price
SA147554	SA 36L738Y754G1	1.000	1,114.00
RA136595	RA 36L738Y754G1	1.000	928.00
36CB1003A01	CONDUIT BOX	1.000	209.00
37GS3011	1/8"WHITE NEOPRENE BOX GS	1.000	5.00
10XN2520A08	1/4-20X1/2 HEX HEAD CAP	2.000	2.00
11XW1032G06	10-32 X .38, TAPTITE II, HEX WSHR SLTD U	1.000	3.00
HW3001A01	D3019 BRASS WASHER(STIMP)	1.000	2.00
36FE1907A01	FR EP ASSY W/EP FROM SOUTHERN TOOL STAIN	1.000	493.00
HW4606A02	JM CLIPPER/SEAL (LWE-0938-1624-AL23)	1.000	46.00
HW5100A05	WVY WSHR F/205 & 304 BRGS	1.000	2.00
36EP1908A03	PUEP, FOR LOCKED 6206 BRG	1.000	595.00
HW4500A33	1/8 NPT STAINLESS,HOLO-KROME #13002,PRES	3.000	3.00
10XN2520S28	1/4-20X 1 3/4 HEX HD SS X	4.000	1.00
HA1049A02	DUBO LOK WASHER SIZE 1/4 (NYLON LOCK SEA	4.000	2.00
HA1049A02	DUBO LOK WASHER SIZE 1/4 (NYLON LOCK SEA	4.000	2.00
36FH4011	WASHDOWN FAN COVER #304 STAINLESS W/NOTC	1.000	61.00
10XN1032S06	HEX HD CAP SCREW, SS	3.000	2.00
36CB4517	36 LIPPED CB LID #304 STAINLESS STEEL	1.000	10.00
37GS3010SP	1/16"WHITE LID GASKET	1.000	2.00
11XN0832S07	08-32X7/16 HX SL WS HD,SS	4.000	3.00
HW4606A03	JM CLIPPER/SEAL (LWE-1156-1875-AL44)	1.000	41.00
HW2502E16	SS KEY 1/4 X 1.750 X	1.000	4.00
HA7000A02	KEY RETAINER RING, 1 1/8 DIA, 1 3/8 DIA	1.000	2.00
MJ5001A02	732 CL SEALANT 3 OZ DIXIE BEARING 289100	0.001	23.00

Parts List (continued)			
Product ID	Description	Quantity	List Price
HW3200S01	EYEBOLT 3/8-16 X3/4 S.S. TDR #35988	1.000	68.00
MJ1000A02	GREASE, POLYREX EM EXXON	0.050	10.00
51XB1214A16	12-14X1.00 HXWSSLD SERTYB	1.000	2.00
HA3101S29	THRUBOLT- 1/4-20X13.00 SS	4.000	13.00
36FN3000C01SP	FAN EXTERNAL,PLASTIC, 5.25 OD, .912/.907	1.000	15.00
LB1125C02	SUPER-E (STOCK CTN LABEL SUPER-E WITH FL	1.000	2.00
36PA1001	PACKAGING GROUP	1.000	25.00
LB1357	ENERGY GUIDE LABEL (BOX LABEL)	1.000	2.00

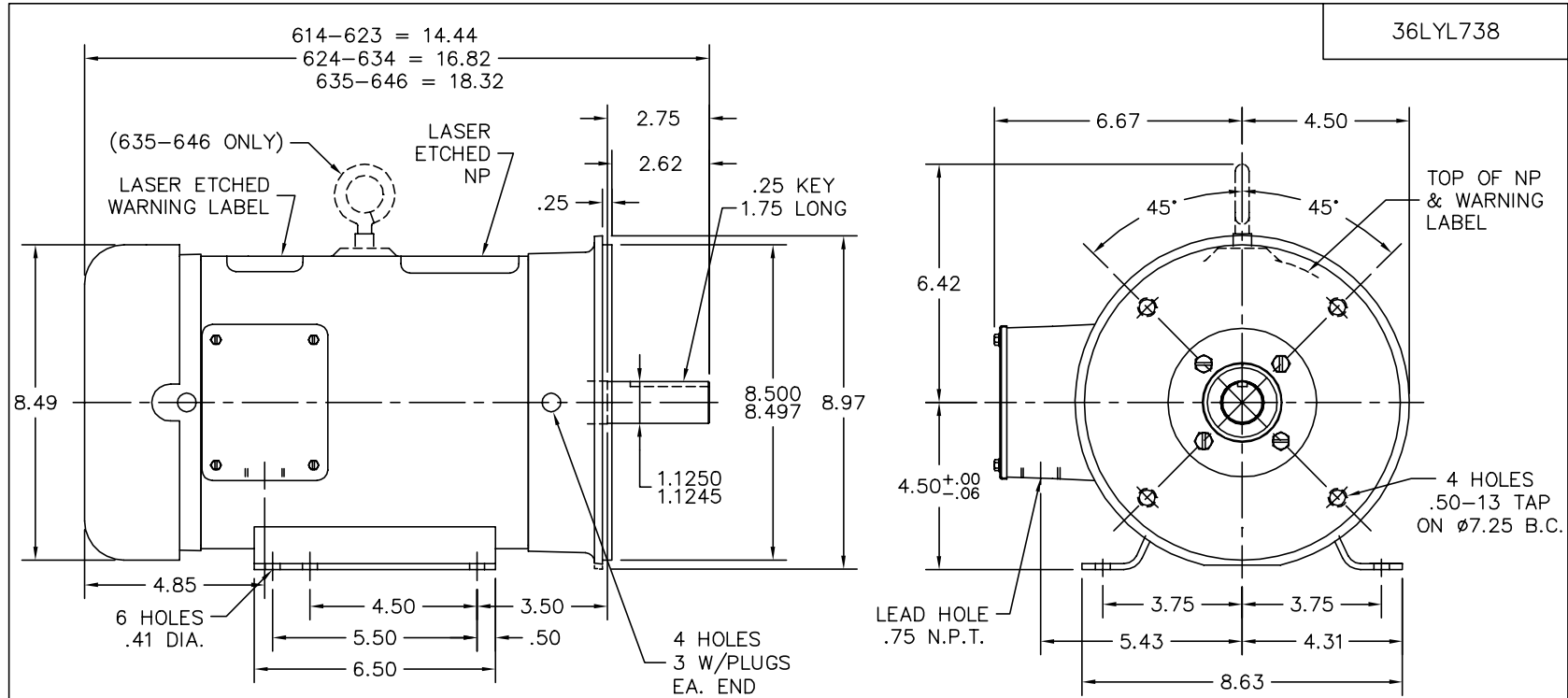

36LYL738

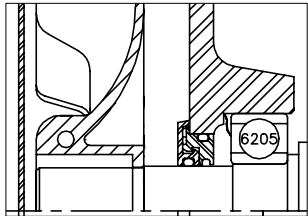

FRONT END DETAIL

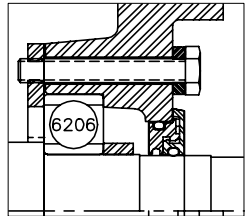

PULLEY END DETAIL

CUSTOMER IS RESPONSIBLE FOR DETERMINING THAT MOTOR PERFORMANCE IS SUITABLE IN THE APPLICATION.

REV. DESC: NEW		
REV. LTR: -	VERSION: 00	TDR: 000000401176
85771795	FILE: \AAA\00138\116	REVISED: 08:21:44 07/19/2006
	MTL: -	BY: ENBRYPO

BALDOR ELECTRIC Co.	
HOR 182-4TC TEFC 36M WD4 W/LOCKED PU.BRG & LASER ETCHED BAND	

36LYL738

CD0005

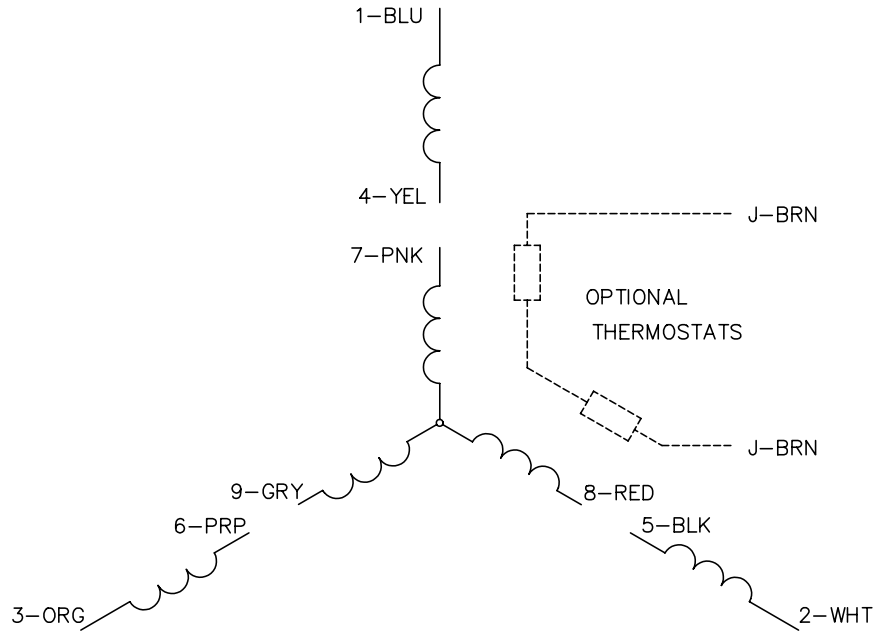

LOW VOLTAGE
(2Y)

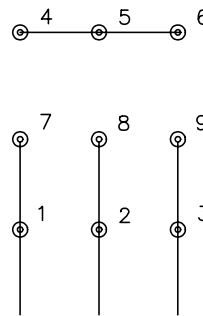

HIGH VOLTAGE
(1Y)

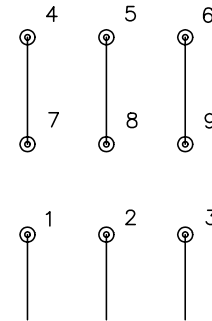

NOTES:

1. INTERCHANGE ANY TWO LINE LEADS TO REVERSE ROTATION.
2. OPTIONAL THERMOSTATS ARE PROVIDED WHEN SPECIFIED.
3. ACTUAL NUMBER OF INTERNAL PARALLEL CIRCUITS MAY BE A MULTIPLE OF THOSE SHOWN ABOVE.
4. LEAD COLORS ARE OPTIONAL. LEADS MUST ALWAYS BE NUMBERED AS SHOWN.

REV. DESC: REVISE TO SHOW OPTIONAL COLORS			
REV. LTR: E	BY: JLP	REVISED: 01/19/99 10:15	TDR: 0171435
90000		FILE: AAA00005140	MDL: -
		MTL: -	

BALDOR ELECTRIC Co.

3PH, DV, 9 LEADS

CD0005